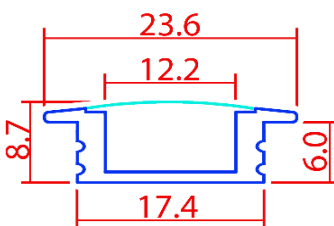
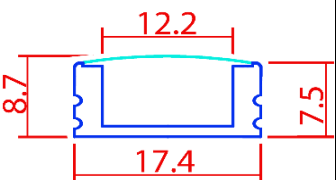
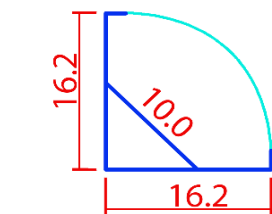
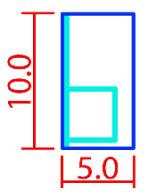

Date:

Customer:	Purchase Order:	Job Number/Reference:
Web Order		
Please include contact details in email or notes section		

Light <u>A</u> Length:	Light <u>B</u> Length:	Light <u>C</u> Length:	Light <u>D</u> Length:
<i>If any lights are sharing a transformer - What ones will be together? Answer in notes</i>			
<input type="radio"/> Transformer	<input type="radio"/> Transformer	<input type="radio"/> Transformer	<input type="radio"/> Transformer
<input type="radio"/> 2m Tail Extension	<input type="radio"/> 2m Tail Extension	<input type="radio"/> 2m Tail Extension	<input type="radio"/> 2m Tail Extension

Lighting Profile

<p style="text-align: center;">Thin</p>  <p style="margin-top: 10px;"> <input type="radio"/> Silver <input type="radio"/> Black <input type="radio"/> White </p>	<p style="text-align: center;">Mini</p>  <p style="margin-top: 10px;"> <input type="radio"/> Silver <input type="radio"/> Black <input type="radio"/> Mounting Clips </p>	<p style="text-align: center;">Corner</p>  <p style="margin-top: 10px;"> <input type="radio"/> White <input type="radio"/> Mounting Clips </p>	<p style="text-align: center;">Flexi</p>  <p style="margin-top: 10px;"> <input type="radio"/> Cool White 6000k <input type="radio"/> Natural White 4000k <input type="radio"/> Warm White 3000k <small>Max Strip Length: 5m</small> </p>
Please provide a plan view drawing for any lights that require mitre cuts .			

LED Ribbon

Ambient	Medium	Bright	Speciality
4.8 watt p/m - 3528 (60)	14.4 watt p/m - 2835 (120)	16.3 watt p/m - 2835 (210)	<input type="radio"/> Dual White <input type="radio"/> RGB+W
<input type="radio"/> Cool White 6000k <input type="radio"/> Warm White 3000k	<input type="radio"/> Cool White 6000k <input type="radio"/> Natural White 4000k <input type="radio"/> Warm White 3000k	<input type="radio"/> Cool White 6000k <input type="radio"/> Natural White 4000k <input type="radio"/> Warm White 3000k	<input type="radio"/> Red <input type="radio"/> Blue <input type="radio"/> Green
			Require a remote control <input type="radio"/>
			4.8 watt p/m 3528 (60)

Accessories

Hand Sensor	Door Sensor	PIR Sensor	Remote Control
<input type="radio"/> Single Quantity: _____ For Light/s: _____	<input type="radio"/> Single <input type="radio"/> Double Quantity: _____ For Light/s: _____	<input type="radio"/> Regular <input type="radio"/> Custom Quantity: _____ For Light/s: _____	<input type="radio"/> Dimmer <input type="radio"/> RGB+W Quantity: _____ For Light/s: _____

Notes / Drawing: